

**LOW
POWER
OP. MODE**

**COMPACT
DESIGN**

UNIVERSAL WIRELESS TEMPERATURE TRANSMITTER THW401



The Universal Wireless Temperature Transmitter THW401 is specifically designed to meet the most rigorous requirements of operation in the industrial process environments. Due to its reduced dimensions, it may be installed in the DIN Form B sensor connection head, in place of the traditional terminal blocks or current loop temperature transmitter.

In its high power mode it can communicate over a long distance range (up to 2Km line of sight).

It accepts the most commonly used temperature sensors.

Dimensions: 23 mm x 45 mm

Weight: Approx. 50g

Material: Nylon 66

Protection Index: IP40

KEY FEATURES

EXTREME LOW POWER

OPERATION MODE FOR LONG BATTERY LIFE

UP TO 2KM DISTANCE (LoS)

TRANSMISSION UP TO 2KM DISTANCE (LoS)

REAL TIME TRANSMISSION

PROCESS AND AMBIENT TEMPERATURE, RF SIGNAL STRENGTH AND BATTERY STATUS

WIDE RANGE SUPPLY VOLTAGE

UNIVERSAL SENSOR INPUT

RESISTANCE THERMOMETERS, THERMOCOUPLES, RESISTANCE-BASED SENSORS AND DC VOLTAGE SOURCES

COMPACT DESIGN

DIN FORM B CONNECTION HEAD MOUNTING

PA123720200-PA123720200.DS.ENG.V01.2.2018

TECHNICAL SPECIFICATIONS

INPUT
RESISTANCE THERMOMETER (RTD) / THERMOCOUPLES (TC)

Measured variable	Temperature
Sensor type	PT100, PT500, PT1000/ E, J, K, N, R, S, T
Units	°C or °F
Connection	1 Resistance thermometer (RTD) in 2-wire, 3-wire or 4-wire system Resistance compensation in 2-wire systems available through software / 1 Thermocouple (TC)
Sensor current	<0.05 mA (50µA)
Response time	<500 ms
Open-circuit monitoring	Always active (cannot be disabled)
Short-circuit monitoring	Always active (cannot be disabled) / Not available
Cold junction compensation (CJC)	Integrated resistance thermometer
Measuring range	Parameterizable (see table "Digital measuring errors") / Configurable (see table "Digital measuring errors")
Minimum measured span	50°C (90°F)
Characteristic curve	Temperature-linear

OUTPUT
RF TRANSMISSION

Transmission frequency	2.4GHz [2400; 2483] MHz
Transmission interval	Adjustable from 1s to 24h
Maximum output power	18 dBm
Sensitivity	-110dBm
Range	2 Km LoS
Modulation	GFSK
Output signals	
Temp probe (RTD or TC)	Temperature °C (°F)
Internal Temp	Temperature °C (°F)
RSSI	Absolute value
Power supply level	Voltage V
Configurable parameters	Sensor type, Transmission interval

MEASUREMENT ACCURACY

Digital measurement errors	See table "Digital measurement errors"
Reference conditions	
Auxiliary power	9V DC ± 1%
Ambient temperature	23°C (73,4°F)
Warming-up time	>5min
Error due to internal cold junction	<0.5°C (0.9°F)
Influence of ambient temperature	
with thermocouples	0.6°C (1.1°F)/10°C (18°F)

OPERATING ENVIRONMENT

Ambient temperature range	-20 to 80°C [-4 a 176°F]
Storage temperature range	-20 to 80°C [-4 a 176°F]
Relative humidity	≤95%, without condensation

HOUSING

Material	Nylon 66
Weight	Approx. 50g
Dimensions	See “Dimensional drawings”
Cross-selection of cables	2.5 mm
Protection type	IP40

FACTORY SETTINGS

Sensor	Thermocouple K
Measuring range	0...100°C (32...212°F)
Transmission interval	300s
Node ID	0
Net ID	0

DIGITAL MEASUREMENT ACCURACY
mV

Sensor	Range °C (°F)	Accuracy (mV)
mV	-8 to 100 mV	<40 μV

DIGITAL MEASUREMENT ACCURACY ¹
RESISTANCE THERMOMETER (RTD)

Sensor	Range °C (°F)	Digital accuracy °C (°F)
PT100	-200 to 850 [-328 to +1562]	0.1 (0.18)
PT500	-200 to 850 [-328 to +1562]	0.2 (0.40)
PT1000	-200 to 350 [-328 to +662]	0.2 (0.40)

DIGITAL MEASUREMENT ACCURACY
THERMOCOUPLES (TC)

Sensor	Range °C (°F)	Digital accuracy °C (°F)
E	-200 to 1000 [-328 to 1832]	1
J	-210 to 1200 [-346 to 2192]	1
K	-230 to 1370 [-382 to 2498]	1
N	-200 to 1300 [-328 to 2372]	1
R	-50 to 1760 [-58 to 3200]	2
S	-50 to 1760 [-58 to 3200]	2
T	-200 to 400 [-328 to 752]	1

POWER SUPPLY

Voltage Range	[5; 24] VDC
Power Consumption (Sleep)	< 0.2 mA
Battery Life	For a 9V battery, with 1200 mAh with a transmission interval of 2 minutes, the battery life is higher than 2 years

¹ The “Digital Measuring Accuracy” is the value after the analog/digital conversion including linearization and calculation of the measured one. An additional error is generated in the output current 4 to 20mA as a result of the digital/analog conversion of 0.025% of the set span (digital-analog error). The total error under reference conditions at the analog output is the sum from the digital-analog error (poss. Thermocouple measurements).

CERTIFICATES AND APPROVALS

EN 61326	Electrical equipment for measurement, control and laboratory use. EMC requirements.
IEC 61000-4-2	Electrostatic discharge immunity test
IEC 61000-4-3	Radiated, radio-frequency, electromagnetic field immunity test
IEC 61000-4-4	Electrical fast transient/brust/immunity test
IEC61000-4-5	Surge immunity test

TECHNICAL DRAWINGS AND INFORMATION

ELECTRICAL CONNECTIONS

RESISTANCE THERMOMETER

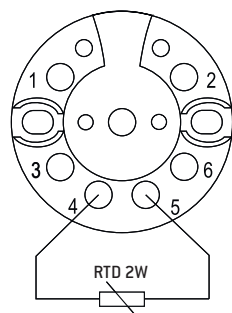

THERMOCOUPLE

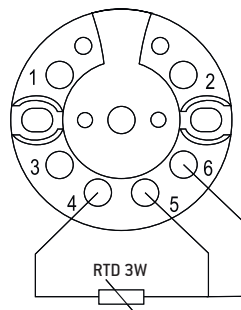
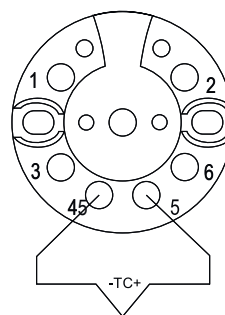

POWER SUPPLY [Uaux]

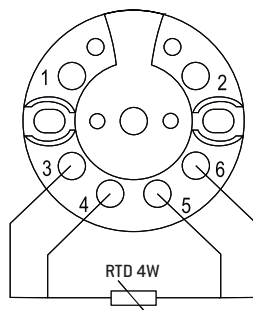
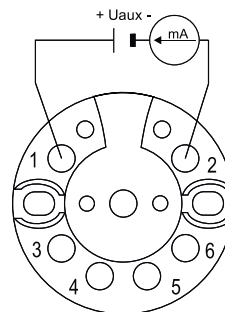

mV SENSOR

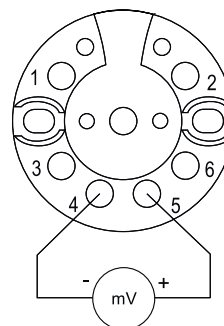

W = WIRES

DIMENSIONAL DRAWINGS

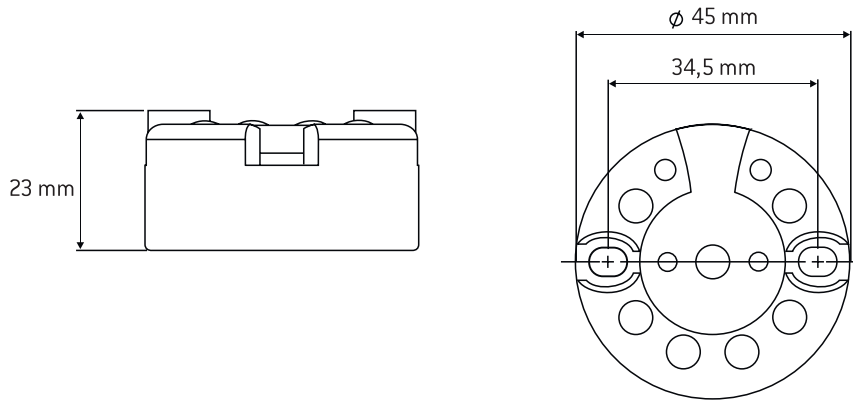

BATTERY LIFE TIME

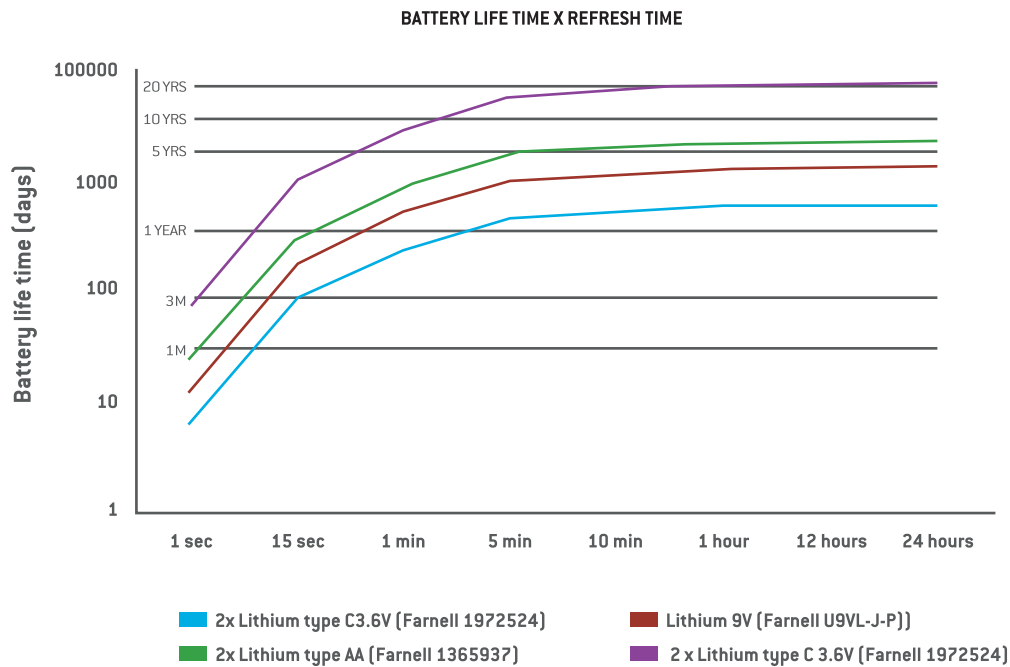

COMPLEMENTARY PRODUCTS



WGW410 WIRELESS MODBUS GATEWAY 2,4GHZ WITH 8 ANALOG OUTPUTS

- Supports up to 16 THW401 temperature transmitters;
- Long distance range (3.5 km LOS);
- 1sec network refresh time;
- RS485 interface with Modbus protocol;
- 8 Analog Outputs;
- Transmitters battery status and RF link quality information;
- Configurable over USB;
- DIN rail mounting.

TEKON ELECTRONICS

a brand of Bresimar Automação S.A.

Quinta do Simão
3800-230 Aveiro
PORTUGAL

P.: +351 234 303 320
M.: +351 933 033 250
E.: sales@tekonelectronics.com

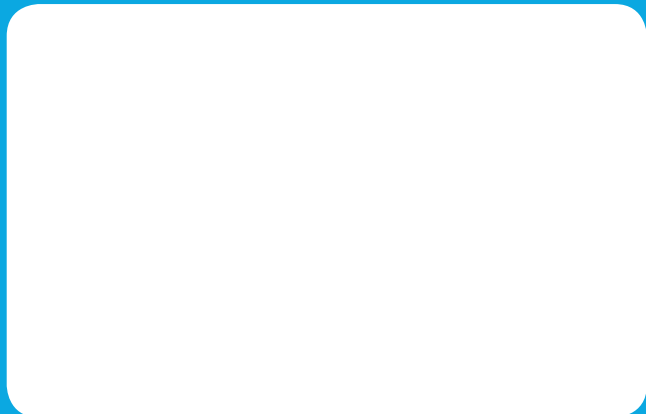

thermo-electra
temperature sensor solutions

Weteringweg 10, 2641 KM Pijnacker, The Netherlands
Phone: +31 15 362 12 00, E-mail: mail@thermo.nl
www.thermo-electra.com